



Rear Cargo Barrier

Piper PA-31 Series

Introduction

The **Aeronautical Engineers Australia** Piper PA-31 Series Cargo Throwover is applicable for use on -350 Navajo model aircraft. The barrier allows the aircraft to be used for cargo carrying operations, securing goods in the aircraft cabin.

Modifications

The net attaches to specially designed hard points and uses a Cordura mesh to restrain small articles between the webbing. This gives a maximum load bearing capacity of 91 kg or 200 lbs. The net can then be easily removed for conversion to passenger carrying or other configurations.

The supplied kit contains the barrier, shackles and all supporting documentation for CASA Australia approval. Separate approval is required for FAA, JAA or other international air safety jurisdictions. The hardpoints require installation by a CASA approved workshop and the aircraft may also require an approved loading system for cargo operations.

Installation View

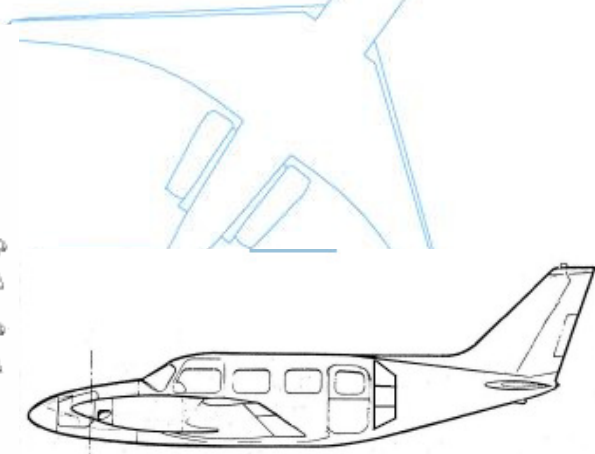
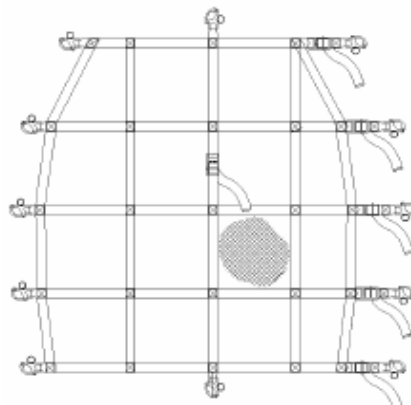

Experience

Aeronautical Engineers Australia has over 30 years of experience in the design and manufacture of aircraft systems and has installed these systems on a wide range of aircraft with numerous examples in service around Australia.



www.aeroengaus.com.au

For more information please e-mail us at cargonets@aeroengaus.com.au. To purchase this product, please contact your nearest **Aeronautical Engineers Australia** office where one of our experienced engineers will advise whether this product is suitable for you and your aircraft.

Aeronautical Engineers Australia

ABN: 61 135 996 253

Perth
Adelaide
Sydney
Brisbane
Melbourne

1C Eagle Drv, JANDAKOT AIRPORT, WA 6164
8 Douglas Drv, Technology Park, MAWSON LAKES, SA, 5095
512 Miles St, BANKSTOWN AIRPORT, NSW, 2200
Unit 4, 18 Redcliffe Gardens Drv, CLONTARF, QLD, 4019
Level 2, 7 English St, ESSENDON AIRPORT, VIC, 3040

Ph: +618 9414 7011
Ph: +618 8260 1322
Ph: +612 9793 9900
Ph: +617 3889 3253
Ph: +613 9091 7599